



MP Series – Mobile Rolling Work Platform

* Available in 6 Standard heights. * Lightweight Aluminum

* 360° Swivel locking caster wheels 8”h x 2”w. * Work platform is 3’0” x 8’8”

* 500 lb load limit * OSHA Compliant * Units can be modified



Series Name	(A) T.O.W.	(B) Overall length	Weight	Part Number
MP-27	27"	10' - 4-3/8"	495 lbs	11786
MP-36	36"	11' - 1-3/8"	534 lbs	11787
MP-45	45"	11' - 10-3/8"	546 lbs	11788
MP-54	54"	12' - 7-3/8"	606 lbs	11789
MP-63	63"	13' - 4-3/8"	620 lbs	11790
MP-72	72"	14' - 1-3/8"	643 lbs	11791

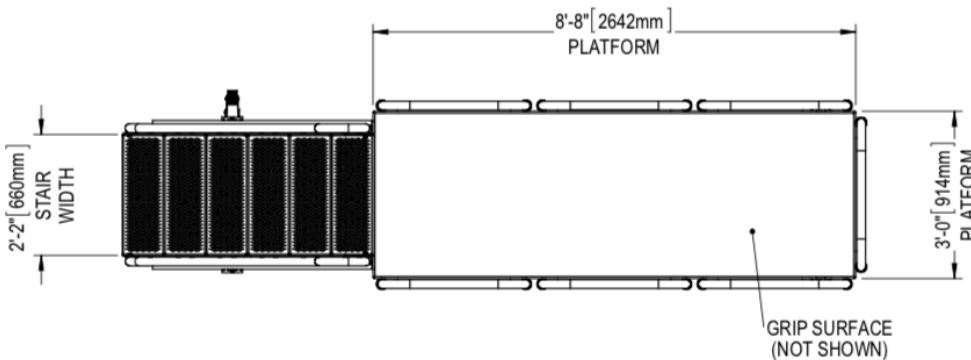
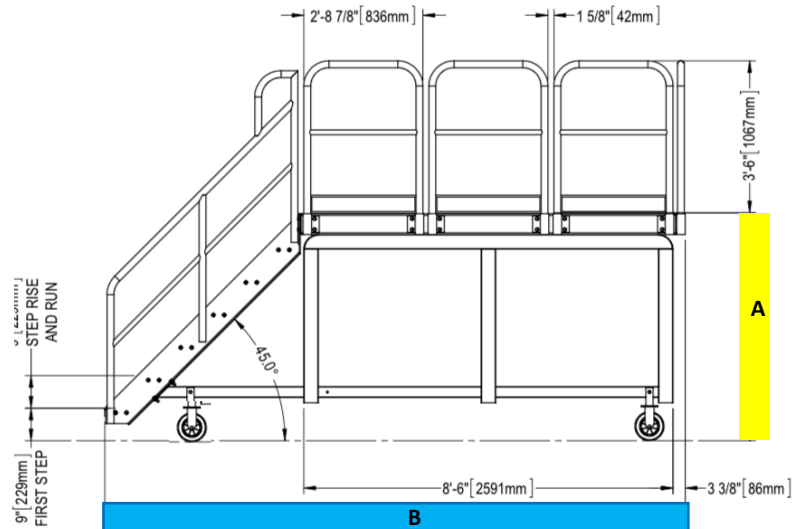

Unlimited modifications can be done to the MP series. Any modifications will change this product to a Modified RS. Modifications will require consultation and review with Engineering.